

## GIFA, METEC, THERMPROCESS, NEWCAST 2023

### Steel industry



In the global steel industry, the blast furnace is at the center of decarbonization. Pictured here at India's Tata Steel.

image: SMS group



Design for the world's first climate-neutral steel mill: H2 Green Steel in Sweden.

image: SMS group

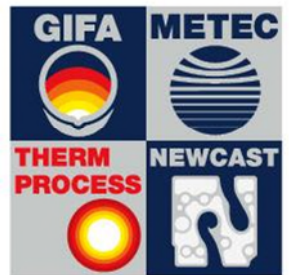

The Bright World of Metals

12–16 June 2023  
Düsseldorf/Germany

15<sup>th</sup> International  
Foundry Trade Fair  
with Technical Forum

11<sup>th</sup> International  
Metallurgical Trade Fair  
with Congresses

13<sup>th</sup> International Trade Fair  
and Symposium for Thermo  
Process Technology

6<sup>th</sup> International  
Trade Fair for Castings  
with NEWCAST Forum

[www.tbwom.com](http://www.tbwom.com)

**M**  
Messe  
Düsseldorf

Messe Düsseldorf GmbH  
Postfach 10 10 06  
40001 Düsseldorf  
Messeplatz  
40474 Düsseldorf  
Deutschland

Telefon +49 211 4560 01  
Telefax +49 211 4560 668  
Internet [www.messe-duesseldorf.de](http://www.messe-duesseldorf.de)  
E-Mail [info@messe-duesseldorf.de](mailto:info@messe-duesseldorf.de)

Geschäftsführung:  
Wolfram N. Diener (Vorsitzender)  
Bernhard J. Stempfle  
Erhard Wienkamp  
Vorsitzender des Aufsichtsrats:  
Dr. Stephan Keller

Amtsgericht Düsseldorf HRB 63  
UST-IdNr. DE 119 360 948  
St.Nr. 105/5830/0663

Mitgliedschaften der  
Messe Düsseldorf:

 The global  
Association of the  
Exhibition Industry

 AUMA  
Messe-Ausschuss der  
Deutschen Wirtschaft

 FKM – Gesellschaft zur  
Freiwilligen Kontrolle von  
Messe- und Ausstellungszahlen

Öffentliche Verkehrsmittel:  
U78, U79: Messe Ost/Stockumer Kirchstr.  
Bus 722: Messe-Center Verwaltung



In the US greenfield project Hybar, a new mini-steel mill in Osceola, Arkansas, will produce reinforcing steel from scrap using 100 percent renewable energy from 2024. For this purpose, the minimill to be built by SMS will be connected to a solar field.

image: SMS group



The world's first hydrogen-based direct reduction: the demonstration plant built in 1999 using Lurgi's (now Metso) Circored technology.

images (3): Metso



The Bright World of Metals

12–16 June 2023  
Düsseldorf/Germany

15<sup>th</sup> International  
Foundry Trade Fair  
with Technical Forum

11<sup>th</sup> International  
Metallurgical Trade Fair  
with Congresses

13<sup>th</sup> International Trade Fair  
and Symposium for Thermo  
Process Technology

6<sup>th</sup> International  
Trade Fair for Castings  
with NEWCAST Forum

[www.tbwom.com](http://www.tbwom.com)





Midrex direct reduction plant of Algerian Qatar Steel in Algerin.

image: SMS group

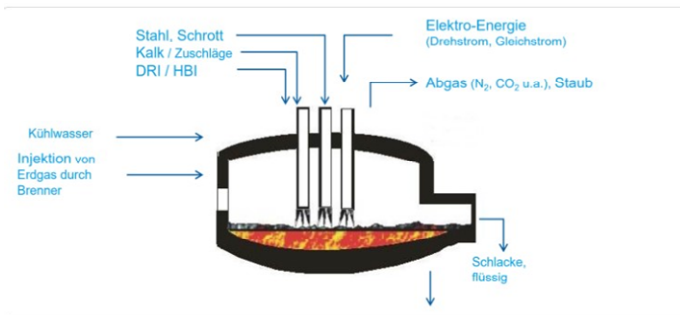

Crude steel production in electric arc furnace.

image: VDEh

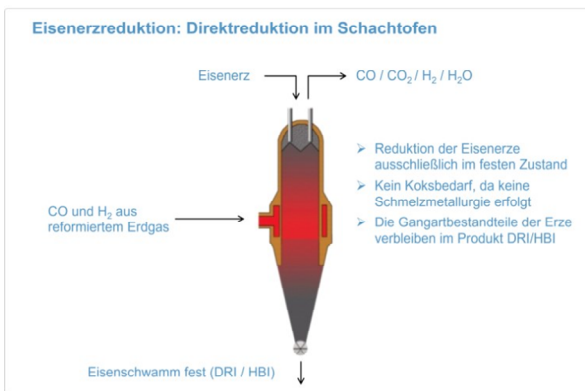

Direct reduction in the shaft furnace.

image: VDEh



The Bright World of Metals

12–16 June 2023  
Düsseldorf/Germany

15<sup>th</sup> International  
Foundry Trade Fair  
with Technical Forum

11<sup>th</sup> International  
Metallurgical Trade Fair  
with Congresses

13<sup>th</sup> International Trade Fair  
and Symposium for Thermo  
Process Technology

6<sup>th</sup> International  
Trade Fair for Castings  
with NEWCAST Forum

[www.tbwom.com](http://www.tbwom.com)



**Carbon direct avoidance (CDA)**

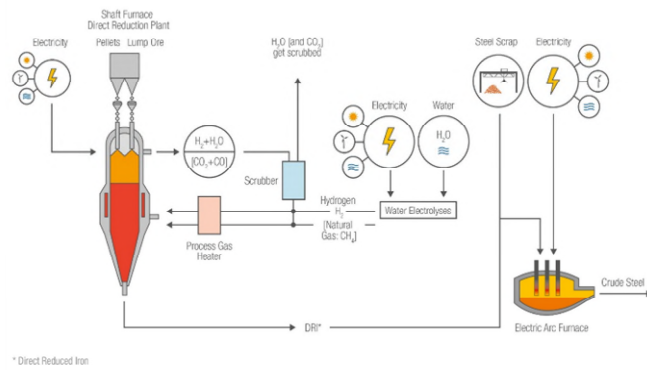

Hydrogen as a reducing agent.

image: VDEh

Foundry Industry



Decarbonization of the melting operation with induction furnace.

Image: ABP

Thermoprocessing

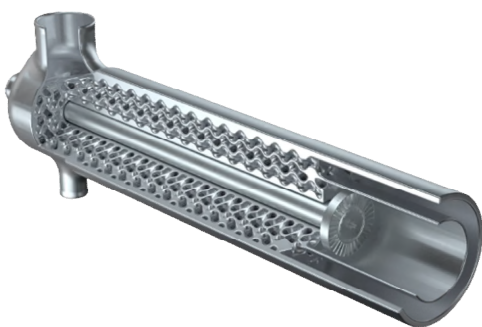

The IRecu recuperative burner is a combination of additively manufactured mixing unit and additively manufactured recuperative burner for maximum fuel flexibility at thermoprocessing plants. The burner efficiently utilizes the residual heat contained in the exhaust gas in counterflow and achieves best efficiencies. Fuels such as coke oven gas or propane/butane can also be used.

image: Kueppers Solutions

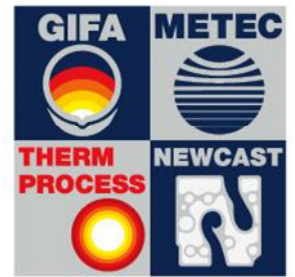

The Bright World of Metals

12–16 June 2023  
Düsseldorf/Germany

15<sup>th</sup> International  
Foundry Trade Fair  
with Technical Forum

11<sup>th</sup> International  
Metallurgical Trade Fair  
with Congresses

13<sup>th</sup> International Trade Fair  
and Symposium for Thermo  
Process Technology

6<sup>th</sup> International  
Trade Fair for Castings  
with NEWCAST Forum

[www.tbwom.com](http://www.tbwom.com)

